

BOARD OF DIRECTORS MINUTES

BOARD OF DIRECTORS MINUTES | Dec. 3-6, 2009

The Board of Directors, Sports Car Club of America, met at SCCA Corporate Headquarters, Topeka, Kan., Dec. 3-6, 2009. The following members participated: RJ Gordy, Chairman, John Sheridan, Vice Chairman, Mike Sauce, Treasurer, Howard Allen, Jim Christian, Philip Creighton, Bob Introne, Robin Langlotz, Michael Lewis, Bob Lybarger, Marcus Merideth, Lisa Noble, and Gerald Wannarka, Secretary. Newly elected 2010 Board members Richard Patullo, Todd Butler, R. David Jones and Bill Kephart also attended. Others in attendance at various times: Jeff Dahnert, President and CEO; Rich Ehert, Vice President of Finance; Eric Prill, Vice President of Marketing and Communications; Terry Ozment, Vice President of Club Racing; Colan Arnold, Vice President of Membership and Region Development; Howard Duncan, Vice President for Rally/Solo and Special Programs; Peter Lyon, Risk Management; Bob Dowie, Chairman of the Club Racing Board; John Bauer and Kevin Yaghoubi, Club Racing Technical Department; and Aimee Thoennes, Executive Assistant.

The Secretary acknowledges that these minutes may not be in chronological order.

Motion: To approve the minutes from the October meeting with the clarification that the Vintage Cage rule proposal was removed. (Wannarka/Allen) PASSED. Unanimous.

PRESIDENT'S REPORT - Jeff Dahnert, President and CEO

Mr. Dahnert shared his belief that in spite of tough economic times especially affecting the automobile industry, the Club did accomplish a lot this past year. We started the year with a new President, moved the Convention to Las Vegas, moved the Solo Nationals to Lincoln, moved the Runoffs to Road America, and still provided high quality competition events. He expressed optimism that the year end financial results will meet earlier projections.

FINANCIALS - Rich Ehert, VP, Finance

Despite difficult economic conditions, the Club is projected to finish the year in the black. The unbudgeted addition of revenue from the seven TransAm races helped the bottom line. Actual numbers will be available at the Convention.

Mr. Sauce reviewed the draft 2010 budget for the Board. The budget is very conservative and is based on a stagnant economy. While the number of competition license holders is projected to decline, there is no budgeted increase in the cost of licenses or sanction fees. The budget is based on a 4% decrease in membership but reflects a 5% increase in the cost of insurance over 2009.

MOTION: To accept the 2010 budget. (Sauce/Creighton) APPROVED, Unanimous

Kevin Arnel from the Club's law firm, Fouston and Siefkin, gave a presentation on the legal issues affecting the Board and Board related governance issues.

RISK MANAGEMENT - Peter Lyon, Legal Counsel

The topic of electronic/internet voting was discussed with the conclusion drawn that it should not be conducted until all of the legal ramifications are more clearly delineated.

Mr. Lyon provided the Board with an update on the Club's insurance program along with an overview of general competition automobile industry programs. It was recommended that the Club stay on the current plan of going out for insurance bids every three years thereby combining the best pricing along with maintaining credibility with the insurance carriers. Our current program is considered to be one of the best in the industry. Last year savings were nearly \$500K, however, there will need to be a 5% increase for 2010. The proposed rate change for Solo will be \$0.50 per car, \$1.50 per car for Club Racing, and \$2.00 per car for Hillclimb. Pro Racing events insurance costs will go up approximately 7%.

MOTION: To accept the 2010 insurance plan. (Sauce/Introne) PASSED, Unanimous.

CONTENTS

BOARD OF DIRECTORS	1
CLUB RACING	31
CRB Minutes	31
Technical Bulletin	33
Court of Appeals	41
Time Trials Administrative Council	None
SOLO	44
SEB Minutes	44
RALLY	47
RoadRally	47
RallyCross	NONE
QUICK LINKS	49

RALLY/SOLO DEPARTMENT and SCCA FOUNDATION - Howard Duncan, VP, Rally/Solo and Special Programs

Rally - It was pointed out that in some Regions, officials are not providing much support for the local RallyCross programs. Regional Executives are encouraged to lend their support to ensure the success of these programs. RallyCross began in earnest five years ago and its growth has somewhat reached a plateau.

Road Rally participation levels remain about the same as those experienced last year. The Rally Boards and Department will be exploring alternative methods of promotion in 2010 to increase participation.

MOTION: To change Appendix A of the Road Rally Rules to read:

Historic Limited (HL) will allow only the following equipment:

- Any mechanical or quartz crystal analog readout timing devices
- Any non-digital odometer can be used for mileage measurements
- Any analog readout speedometer for speed measurement
- Computation equipment is limited to any standard slide rule type devices and/or tables or books. The Curta (and similar) mechanical calculator is permitted. The Halda Speedipilot is likewise permitted.

(Allen/Langlotz) APPROVED, Unanimous

Solo - Regional sanction numbers are maintaining steady with the possibility of finishing the year slightly higher than the number of events scheduled in 2008. The Tire Rack National Solo program Tour was down only a few percentage points, ProSolo was up nearly 12%, and the National Championship up almost 10%. An early initiative has begun to explore conducting Solo events and Tire Rack Street Survival programs at local military bases. While in its infancy, this appears to be gaining some support from the military and will provide exposure of the SCCA to a lot of young military service members.

Planning efforts have begun for the 2010 Tire Rack National Championships at Lincoln. This will be the start of the third year of a three year contract with Tire Rack for support of the National Solo.

MOTION: To accept the proposed SEB rule changes and addendum as listed in Appendix A.

(Noble/Langlotz) PASSED, Unanimous

SCCA Foundation - Plans are underway to increase the activity of the Foundation for 2010.

MARKETING AND COMMUNICATIONS DEPARTMENT REPORT - Eric Prill, VP Marketing and Communications

The Department is actively seeking contingency sponsors for 2010. Serious negotiations are under way with several candidate sponsors. DVD sets of the Runoffs Speedcast coverage became available for purchase on the Club's web site November 17th.

The new Membership Demographic profile was distributed for Board review. This will be a useful document for discussions with prospective sponsors. Twenty seven percent of the membership solicited responded to the survey.

MEMBERSHIP AND REGION DEVELOPMENT - Colan Arnold, VP, Membership and Region Development

The latest schedule of events for the Convention was reviewed. Noteworthy was the addition of a Driver's Tract for this year's event with plans to expand this concept for future Conventions. The 2011 Convention will run February 10 - 12.

It was noted that there were inconsistencies in the re-imbusement plan for registration fees for Program Board members and Board of Directors required to attend the Convention.

MOTION: To pay the registration fees for Program Board members required to attend the Convention. (Sauce/Noble) PASSED, Unanimous

An agreement has been reached with FedEx Office (formerly Kinkos) which will provide significant discounts on printing and copying to Regions and the Club Office. The electronic E-Newsletters InsideLine and the new Road Rally newsletter have been re-formatted.

The August membership was 45,043, a 6.9% decline since the first of the year. The good news is in recent months the number of new members has returned to levels seen in mid 2008 and better than 2007. The referral program is considered to be quite successful and has resulted in about 2500 new members per year. Additional charts and graphs describing various aspects of the membership demographics were presented.

CLUB RACING REPORT - Terry Ozment, VP, Club Racing

RUNOFFS - Results of the post event competitor survey were discussed. In spite of a few issues, it was considered by all to be an outstanding event. The planning for next year has already started, and efforts will be initiated to address the items of concern

that were noted.

Converting Monday of Runoffs week from a test day to a qualifying day will have a negative impact on monies available for the Tow Fund. Additional funding will be pursued to try and offset some of the loss.

MOTION: Pay out the event money collected during the year for the Runoffs and search for other funding for the 2010 Runoffs. (Sheridan/Sauce) PASSED, Unanimous

Volunteer Task Force - This effort by the Club Racing Department to assess the Club's race organization structure and event operational requirements has been put on temporary hold because of time constraints. It is still an item of interest that will begin again after the new year.

The Track Review Program training is completing its last phase under the grant received from FIA. The last product will be a manual that can be shared with new and prospective track owners on basic information for what the requirements are for a racing facility meeting the SCCA's needs

The Spec Miata Compliance Program is winding down. Sixteen compliance visits were made in 2009 leaving a surplus of about \$14,000. The Spec Miata community has requested that a portion of these funds be used to support fuel testing in 2010.

There will be a change in processing of sanction requests for 2010. The Division Executive Steward will be responsible for ensuring that the Supplemental Regulations for the event are in compliance with the GCR. The Club Office will no longer be responsible for GCR issues, rather their efforts will be directed to the sanction process itself. This should expedite processing of the sanction packets. This change will require the following change to the Operations Manual.

John Bauer introduced the new electronic letter system which will simplify and expedite the processing of rules change requests to the CRB. The requesting party will not be able to determine the status of their request by going on line using this system. The BoD suggested that this process may also have utility with the rules processes for the other Program Boards.

The CRB is exploring options for a two year competition license. The requirement for annual physicals may prohibit older drivers from participating in this plan should it come into being.

EXECUTIVE STEWARD ISSUES

The current process and timelines for appointing Executive Stewards have created some problems in several Divisions.

MOTION: Change 5.4.1 of the Operations Manual (Executive Stewards) to read:

Appointment: One per Division, appointed by the Area Director(s) for each Division, upon advice from the Chairman of the Stewards Program and final acceptance by the Board of Directors at their first meeting after the Runoffs. Term to begin on the day of their appointment. A separate provision: for new incoming Directors have a December meeting appointment date for their Executive Steward selections. (Creighton/Lewis) FAILED, For: Creighton, Noble, Merideth and Lewis. Opposed: Christian, Introne, Allen, Sheridan, Gordy, Lybarger, and Wannarka. Abstentions: Langlotz and Sauce.

After discussion, it was decided that this issue should be sent to the Executive Stewards for their recommendations as to how to best handle appointment dates.

MOTION: To approve the following changes to the Operations Manual.

5.4.1 Executive Stewards: Review and approve supplemental regulations, race schedules, and entry forms for race sanction requests prior to submission to the Club Racing Department. (Creighton/Merideth) PASSED, Opposed: Allen and Langlotz.

CRB RULE RECOMMENDATIONS - Bob Dowie, Chairman, Club Racing Board

The CRB has discussed the quantity verses quality concepts for attendance at the Runoffs, and while no overwhelming conclusion could be reached, they favored promoting larger attendance at the Runoffs. The thinking is that more competitors will result in more competition. Their recommendation for qualifying is 4 starts, 3 finishes and 4 Divisional points but drop the requirement for finishing in the top 10 for that class within the Division. An extended discussion ensued pertaining to the health of the National Racing program and the Runoffs.

Proposed rule changes for Club Racing are listed in Appendix B.

MOTION: To accept the rules changes, except item 6, as proposed by the CRB. (Merideth/Wannarka) PASSED Unanimously (Sheridan abstaining on AS issues)

MOTION: To accept item 6. amended as a minimum of 4 starts and 4 finishes with no minimum Divisional points. (Creighton/Sauce) PASSED, Opposed: Merideth, Lybarger and Introne.

MOTION: To mandate the use of Head and Neck Restraints certified by SFI or FIA in Club Racing as of 1/1/12. (Creighton/Allen) PASSED, Opposed: Sauce, Lybarger, Langlotz, Gordy and Introne. Abstention: Noble

MOTION: To grant a waiver to CENDIV to waive the provisions of the GCR (3.2.2.d and e) which precludes Regions running multiple Nationals at the same track (Road America). (Lybarger/Sauce) PASSED, Opposed: Merideth and Allen. Abstention: Langlotz.

MOTION: To grant a waiver to CENDIV to waive the provisions of the GCR (3.2.2.d and e) which precludes Regions running multiple Nationals at the same track (Blackhawk Farms). (Lybarger/Sauce) PASSED, Unanimous.

MOTION: To grant a waiver to Oregon Region to waive the provisions of the GCR (3.2.2.d) allowing the Region to have three Nationals. (Allen/Gordy) PASSED, Unanimous.

MOTION: To grant a waiver of the GCR (3.2.2.d and e) to the Houston Region to have two Double Nationals at MSR Houston. (Sauce/Allen) PASSED, Unanimous.

MOTION: To grant a waiver of the GCR (3.2.2.d and e) to the Colorado Region to have two Double Nationals at High Plains. (Christian/Sauce) PASSED, Unanimous.

LIAISON REPORTS

SOLO EVENTS BOARD LIAISON REPORT - Noble

As part of the 10 event 2010 Tire Rack Solo National Tour, a Northern States Championship has been added to the list of three events that can qualify drivers for the solo Triad award. These events are:

- Peru, Indiana - Northern States Championship
- Wendover, Utah (tentative) - Western States Championship
- Blythville, Arkansas - Eastern States Championship

The SEB and Kart Advisory Committee are reviewing the Junior Kart Training Guidelines to bring about better continuity between Regions.

There are a handful of fixes for the 2010 rules package passed in October. These include errors in transcription or of omission as well as items that did not make the earlier package. The SEB wishes these to be a part of the 2010 Rule Book.

CLUB RACING LIAISON REPORT - Merideth/Wannarka

The CRB had its Fall face to face meeting in Kansas City November 21/22. Main objective of the meeting was to begin the process of long range planning for how the CRB envisions the Club racing program to look like in the out years. Time was also spent discussing the Runoffs and what improvements should be considered for next year.

STEWARDS REPORT - Introne

Last call was devoted to discussing the Runoffs.

TIME TRIALS ADMINISTRATIVE REPORT - Merideth

Requested the Board approve the TTAC rules proposals. Proposed rule changes have been out for member notice and input.

MOTION: To accept the Time Trials Administrative Council rules changes (Appendix C) (Merideth/Noble) PASSED, Unanimous.

OLD BUSINESS:

The GCR re-write was initially presented to the Board at its October meeting. There were a number of technical issues that were identified, and the document went back to the GCR Advisory Committee and the Executive Stewards to address these issues. The update version was again presented to the Board in December.

MOTION: To accept the GCR rewrite effective 1/1/2011. (Creighton/Sauce) FAILED, Creighton and Sauce yes, Others no. The consensus was to get the document approved for the 2010 season.

MOTION: To accept the GCR rewrite with the modifications as listed below effective 1/1/2010. Items listed will revert back to the original language until the proposed new language can be acted upon and member input acquired if necessary. (Langlotz/Allen) PASSED, Opposed: Christian and Creighton.

Paragraphs requiring additional review:

3.3.b

5.9.3

5.12.b
5.12.c
6.4.1.e
6.7.2
7.2

AMERICAN SEDAN INCIDENT REPORT

The report based on assessments made by the committee made up of Messers Nesbitt, Corbitt, Wheeler, Prather and Bornholts, Chairman, pertaining to the American Sedan issues at the Runoffs was reviewed by the Board. The report was considered to be quite objective and informative. The Board would like to see the recommendations given serious consideration by those responsible for subsequent Runoffs to ensure that a repeat does not happen again. The Chairman of the Committee will be asked to draft a document that can be used as a 'release' statement summarizing the committee's findings and recommendations. The Board would like to complement and thank the committee for the timely and thorough manner by which they completed this task.

NEW BUSINESS:

The Board selected the Member of Excellence awardee. Now in its second year, funding was provided by a anonymous benefactor who wanted to give back to the club for the many fun years experienced in club activities. The award is to be given to an individual who over the years has made important contributions to the club but has yet to be recognized for their efforts.

COURT OF APPEALS REPORT - Bob Horansky, Chairman

The Court prepared a summary of 2009 appeal activity for the Board's review. The overall activity was similar to that experienced in 2008. The number of rules interpretations were lower than last year.

PLANNING COMMITTEE REPORT - Jerry Wannarka, Chairman

The Planning Committee has been discussing activities which would assist Regions in developing and expanding programs that will enhance their financial health. The Committee requested that the Staff survey the Regional Executives prior to the Convention asking what they think their program needs are and what the Club office could do to help them. This information will then be used as agenda items for the RE/Board meeting at the Convention.

The Club lacks the metrics to determine the health of our Regions. The Committee will be working to develop these items so that a proper method of assessing impact on Regions can be put in place.

A number of Regions are struggling with the cost impact of putting on driver's schools. The Committee asked that the Club Racing Staff be tasked to explore ways that driver school credits could be obtained during a series of Regional race weekends.

The Club Office staff has been asked to develop a matrix that would compare cost and benefits to competitors by joining the various sanctioning groups and marquee clubs.

Program Boards and Liaisons are reminded that their Strategic/Tactical plans should be updated for Board review at the Convention. They should also be prepared to discuss how their 2009 program meets their Tactical Plan goals, what their plans are for 2010, and what is their biggest challenge.

The number of National competition events that the Board of Directors is expected to attend is increased while the expense re-imbursement plan has remained the same.

MOTION: To increase the days eligible for re-imbursement to attend National Championship events from seven to twelve. (Wannarka/Lybarger) PASSED, Opposed: Creighton, Noble, Allen and Lewis. Abstain: Sauce and Christian

MOTION: To adjourn,

Gerald Wannarka
Secretary

Appendix A. Solo Events Board Rules Changes plus Addendum
Appendix B. Club Racing Board Rules Changes
Appendix C. Time Trials Administrative Council Rules Changes

Appendix A: SEB Rules Changes

GENERAL CATEGORY

ITEM 1) Withdraw the two previously approved rule change proposals concerning roll bars in Solo vehicles for 2010:

~~ITEM 2) 3.3.2, second sentence — Change: “A roll bar meeting the requirements of Appendix C or a roll cage meeting the requirements of Section 9.4 of the Club Racing General Competition Rules (GCR) is required in all non-production vehicles in A, B, C, and F Modified classes vehicles and in all open cars using non-DOT tires in the Prepared Category and in D and E Modified classes.”~~

~~SCCA Fastrack News July 2009 Page 15~~

~~ITEM 3) 3.3.2, first paragraph, last sentence — Change: “For open cars in the Stock, Street Prepared, Street Touring, and Street Modified categories using DOT tires, the roll bar or roll cage height may be reduced from Appendix C or GCR Section 9.4 requirements to the highest possible height which fits within an installed factory-specified hardtop or convertible top.”~~

~~SCCA Fastrack News July 2009 Page 15~~

Comment: These changes as submitted and approved may have inadvertently created a possible loophole allowing a configuration which was not intended and may create a safety concern. The SEB would like to withdraw these two items for further study and re-work the proposals to be resubmitted at a later date for the 2011 Solo Rules.

SCCA Fastrack News September 2009 Page 16

STOCK CATEGORY

ITEM 2) Withdraw the previously approved classification change proposal of the BMW 335i for 2010:

~~ITEM 14) Appendix A — Move from FS to DS: BMW 335i~~

~~SCCA Fastrack News September 2009 Page 16~~

Comment: This move was published in Fastrack News as a proposal for 2011 and was included in the Action Items for 2010 in error. The SEB would like to withdraw this proposal.

SCCA Fastrack News September 2009 Page 16

SCCA Fastrack News November 2009 Page 21

ITEM 3) Withdraw the previously approved classification change proposal of the Porsche Boxster S (2000-04) (986 chassis) for 2010:

~~ITEM 57) Appendix A, move to BS from AS:
Porsche~~

~~Boxster S (2000-04) (986 chassis)~~

~~SCCA Fastrack News April 2009 Page 25~~

Comment: After member comments and further study, this move of the Porsche Boxster S was recommended to be rescinded by the Stock Advisory Committee on 9/15/2009 and approved by the SEB. The proposal was submitted to the BOD in error. The SEB would like to withdraw this proposal.

SCCA Fastrack News October 2009 Page 9

SAFETY

ITEM 2) Amend the previous proposal concerning helmets in Solo events for 2010:

4.3.1, first sentence – Change: “All helmets meeting the following standards must be worn while on course: All helmets meeting the current or two immediately preceding Snell Foundation standards (SA, K, or M SA2005, SA2000, SA95, M2010, M2005, M2000, M95, K2005, K98), or SFI standards 31.1A, 31.2A, 41.1A, or 41.2A, or British spec BS6658-85 type A/FR are acceptable. Helmets meeting British spec BS6658-85 A/FR are also acceptable.”

~~ITEM 8) 4.3.1, first sentence — Change: “Helmets meeting one of the following standards must be worn while on course: Snell SA2010, K2010, M2010, SA2005, K2005, M2005, SA2000, K2000, M2000, SA95, K98; SFI 31.1, SFI 31.1A, SFI 31.2A, SFI 41.1, SFI 41.1A, SFI 41.2A; BS6658-85 Type A/FR.”~~

~~SCCA Fastrack News April 2009 Page 24~~

Comment: After receiving member comments, the Snell Helmet Safety Standards were re-examined with a follow-up e-mail

to the Snell Memorial Foundation. Because of changes in helmet testing, Snell will have two concurrent motorcycle helmet standards in effect – M2010 helmets are available now and also M2005 helmets will continue to be certified through June 30, 2011. (This is the same ending date for certification testing of SA2005 and K2005 helmets.) Basically, Snell will have an unusual situation in 2010 – two current motorcycle helmet standards at the same time.

ADDENDUM

GENERAL CATEGORY

- **ITEM 2)** Change Section 4.1.B to: “Drivers are responsible for knowing and understanding the SCCA National Solo Rules. Ignorance of the rules will not be accepted during any adjudication of issues regarding event operations, vehicle compliance, driver/crew behavior, or any other topics. It is strongly recommended that drivers have a copy of the current rules at all SCCA Solo events, especially at Divisional and National level events.”

Comment: The previous rule, which had been in place for over 30 years, has become increasingly less relevant with the advent of the rules being available on the SCCA web site and has come to be viewed as an unneeded bureaucratic requirement for entrants to show their rule book at registration. However, the revenue generated from rule book sales has been used to offset a portion of the costs associated with the development and maintenance of the rules, including Tech Services. Therefore, this revenue will be replaced by increases in National Solo entry fees and the optional Solo License. The Solo Rules will continue to be available for purchase in their traditional book form.

To change Section 4.1.B to: Drivers are responsible for knowing and understanding the SCCA National Solo Rules. Ignorance of the rules will not be accepted during any adjudication of issues regarding event operations, vehicle compliance, driver/crew behavior, or any other topics. It is strongly recommended that drivers have a copy of the current rules at all SCCA Solo events, especially at Divisional and National level events.

Appendix B: CRB Rules Changes

STATUS OF WORK ITEMS

GCR Revision: The GCR Advisory Committee has reviewed comments received from BoD members and Executive Stewards. Their responses have been submitted separately. The CRB recommends adoption of the revised GCR as submitted. (See next item for Appendix C changes.)

15 Year-Old Permits: Some adjustments to the GCR language have been made in response to staff requests as a result of their efforts to implement the program. As approved by the BoD in November, a 15 year-old who satisfies the requirements for issuance of a National license would continue to carry the permit until reaching the age of 16. The staff would prefer treating the 15 Year-Old Permit in the same way as the existing Novice Permit – upon completion of the requirements for a National license, the permit would be replaced by a National competition license and the logbook would no longer be necessary. Two versions of Appendix C and related changes to other parts of the GCR are attached to implement either method depending on the BoD's preference. (The two versions begin on pages 16 and 22.)

Safety Harness Expiration Extension: No new information.

Head and Neck Restraint Implementation Plan: In response to the BoD's request for a plan to implement mandatory head and neck restraints, the CRB notes that it recently recommended not adopting a mandatory rule, but supports strongly encouraging the use of head and neck restraints. The CRB confirms that recommendation now. If a mandatory requirement is to be added, we suggest that it be effective 1/1/2011 and only head and neck restraints that are FIA or SFI 38.1 certified be accepted.

Runoffs Invitations: The CRB recommends that the qualifications for Runoffs eligibility for 2010 be modified so that competitors are required to start four National races and finish 3 of those races (as was the case prior to 2009). In addition, the CRB recommends the requirement that competitors be among the top ten in their class in their division of record be removed. Specific language for these recommendations is included below.

2010 Runoffs Schedule: At its October meeting, the BoD voted to include all National classes to participate in the 2010 Runoffs. Our goal is to have as few combined race groups as possible, but because of the limited number of sessions available, it is possible that in one case we may need to combine three classes in one race group. This is due to the inclusion of STO and ST, both of which can be grouped well only with T1.

Proposed Rules Changes

GCR – December

Item 1. Effective 1/1/10: Change Note 2 of section 9.1.12, as follows:

For the purposes of this section, ~~GTL shall be considered a new class from 2006~~; T3 and Spec Miata *shall be considered new classes* from 2006 and STO, and STO, STU, FE and Formula 1000 from 2007.

Housekeeping changes.

Item 2. Effective 1/1/10: To meet the requirements of the motion passed by the BoD, change section 3.9.2.E, as follows:

~~Those classes attaining an average of 2.5 cars or better per race, as defined in 9.1.12, in the previous year of national racing shall be invited to the following year's Runoffs. All National classes are invited to the Runoffs. If there are not at least 10 Runoffs entries in a given class, a National Champion will not be recognized in that class.~~

Housekeeping changes.

Item 3. Effective 1/1/10: In 9.3.26.A, Prohibited Compounds table, change the allowed amount of benzene from 2.0% to 5.6%.

The EPA allows up to 4.9% benzene by volume (5.6% by weight) to be sold in areas that do not require reformulated gasoline. The EPA expects to lower that level in the next few years, but our competitors who use street fuels might currently encounter higher levels of benzene than we would prefer to allow.

Item 4. Effective 1/1/10: Modify 3.9.1.F.4 (revised GCR) as follows:

4. Change of Division. A driver may change his Division of Record by separately notifying in writing the Club Racing and the Membership Departments in the National Office, and his newly designated Region of Record in the incoming division prior to the beginning of the third National race *weekend* in either the incoming or the outgoing division – whichever is earlier. It is the driver's responsibility to ensure that all three parties are notified within the allowed time.

Multiple double National weekends early in a division's season may cause competitors to miss the current deadline.

Item 5. Effective 1/1/10: Modify pages ii and iii to reflect the intent to make the electronic edition of the GCR the primary reference. Please see attached revisions on page 13.

Housekeeping changes.

Item 6. Effective 1/1/10: Modify 3.9.2 as follows:

3.9.2. SCCA Runoffs

SCCA schedules and conducts an event each year called the SCCA Runoffs, open to ~~the highest placing~~ *all* drivers from each Division Championship who meet the invitation qualifications. The SCCA Runoffs are conducted under the provisions of 3.1.1. and determine the SCCA National Champion in each eligible class.

SCCA publishes the Supplemental Regulations defining driver and car eligibility and other event details.

A. Invitations to the SCCA Runoffs

Invitations are issued to ~~the highest placing~~ *all* drivers in each Runoffs-eligible class in each Division Championship based on the following minimum qualifications:

1. The driver must *start at least 4 National races and* finish at least ~~4~~ 3 National races in the current race season.
2. At least 2 of these 4 National races must have been in his Division of Record.
3. He must qualify in the same class(es) in which he is entering the Runoffs, though he may compete in any car eligible for the class(es).
4. If a driver has designated a division/class combination for additional class qualification, he must meet the requirements of 3.9.1.A. and 3.9.1.F.3.

These changes are to implement the CRB's request regarding Runoffs invitations.

Touring/Showroom Stock – November

Item 7. Effective 1/1/10: Add the following sentence to the end of section 9.1.7.E.8:

Cars equipped with lug bolts may convert to wheel studs and lug nuts.

Some cars with lug bolts have been experiencing loosening of the bolts. This is purely a safety-related change.

American Sedan – December

Item 8. Effective 1/1/10: Change section 9.1.6.D.4.d.9, as follows:

The use of offset steering rack bushings is permitted. ~~Offset tie rod ends for bump steer correction are allowed. Tie rods and tie rod ends may be modified or replaced.~~ Spindles may be machined so that tapered tie-rod end bolts can be replaced with straight bolts.

This allows consistent implementation of alternate rod ends across all cars in class.

Item 9. Effective 1/1/10: Clarify 9.1.6.D.1.l and 9.1.6.D.1.m as follows:

- l. Cylinder head to intake/exhaust manifold port matching is permitted. No material shall be removed from the cylinder head(s) further than one (1) inch in from the manifold to cylinder head mounting face(s). External dimensions of the cylinder head or intake/exhaust manifold shall not be reduced to facilitate internal porting. *The throat area of the port consists of a single cut up to a maximum 90 degree angle at the very bottom of the steel valve seat as it transitions to the aluminum or cast iron casting below ("Throat Cut"). It is permitted to plunge cut the throats in order to correct for core shift that is commonly found in many cylinder heads. This cut cannot extend further than .800 inches below from the top of the ferrous valve seat. There can be no tooling or machine marks in the head below this point. The area where the cut meets the floor of the cylinder head port cannot be blended by hand, machined or chemically processed to create a smooth transition at this point. No aluminum or cast iron in the bowl area (other than that specified for the plunge cut) or the ports may be removed, added or manipulated for any reason. It is understood that many heads may look slightly different from bowl to bowl due to casting irregularities. No material may be removed or added from the short turn radius in the port.*

Any modification of the cylinder head beyond that permitted in ~~Section D.1.l., (below)~~ in this section and Section F. (Engine Build Sheets) is prohibited. See Section F – Engine Build Sheets for additional specifications.

Valve guide material is unrestricted.

Milling of the cylinder head to increase compression ratio is permitted.

Any or all valve seats may be replaced. Valve seat material must be ferrous.

The combustion chamber may be repaired or modified in the area shown in Section F – Engine Build Sheets, Drawing 2 to repair or prevent pitting or damage between the intake and exhaust valves. This repair/modification may serve no other purpose.

- m. ~~Solid, one-piece steel or stainless steel (no titanium/titanium alloy) intake and/or exhaust valves are permitted. Only stock, steel, or stainless steel intake and exhaust valves are permitted. Titanium or titanium alloy valves are not permitted.~~ Valve seat specifications shall comply with Section F – Engine Build Sheets, Drawing 1. *Valve length and valve stem installed height is open. Any valve seal may be used. A valve job will consist of 3 valve angles ("Valve Angles") only not including the Throat Cut angle. Each of these Valve Angles is open. The widths of the Valve Angles on the head and on the valve are open. The Valve Angles must not extend off the seat into the aluminum or cast iron casting at the top or bottom of the seat. Additional valve specifications are listed in Section F – Engine Build Sheets.* ~~Valve and~~ Valve seat specifications shall comply with Section F – Engine Build Sheets, Drawing 1 & 2.

These changes are intended to clarify what modifications may be made to AS cylinder heads. They are a direct result of issues encountered at the 2009 Runoffs. The figures for these sections are attached.

Spec Miata – December

Item 10. Effective 1/1/10: Add the following sentence to the end of section 9.1.8.C.1.f:

The OEM clutch line may be replaced with a steel braided line.

Allows Aeroquip type clutch lines to mitigate costs of failed OEM lines.

Item 11. Effective 1/1/10: In an effort to clarify the Miata engine rules, remove the current section 9.1.8.C.1 in its entirety and replace it with the following:

C. AUTHORIZED MODIFICATIONS

The following items represent the only modifications and safety items permitted and/or required on Spec Miata automobiles other than safety items as required in Section 9. Permitted components or modifications must not perform a prohibited function. Updating or backdating is not allowed for any car, model, specification, or component, except as specifically authorized in these rules.

A Mazda factory shop manual for the specific make, model, and year of automobile is required to be in the possession of each entrant. The manual may be in the form of printed material, microfiche, CDs, DVDs, and/or Internet access to manufacturer sponsored web-based databases. The manual is intended to aid scrutineers in identifying parts and the configuration of the

automobile.

All engines and internal components used in rebuilding or refurbishment must have been offered for sale by Mazda in the US for the correct year and VIN of car, except as otherwise provided for in these rules. This rule prevents use of aftermarket parts or Mazda parts of incorrect specification or application.

Assembly, rebuild, and refurbishment procedures, and all associated dimensions must adhere to the published factory service procedures, except as otherwise stated in these rules. No components may be added or omitted from those specified by the published factory service procedures. All components must be standard dimensions.

Any water pump, timing belt, or alternator of original equipment manufacturer design, dimensions, and specification may be used.

The use of any painting, coating, plating, or impregnating substance (e.g., anti-friction, thermal barrier, oil shedding coatings, chrome, anodizing, etc.) to any internal engine surface, internal transmission or differential surface, internal or external surfaces of the exhaust manifold or down tube is prohibited.

If the factory manual or these rules provide only a partial specification or no specification at all, the Mazda parts may not be modified beyond what is allowed in these rules. Compliance of such parts will be determined by comparison to new parts delivered by Mazda. Other approved parts with only a partial specification or no specification available in these rules may not be modified. Compliance of such parts will be determined by comparison to new parts from the supplier.

1. Engine Modifications

a. General

- 1) No modifications to this engine are allowed, except where specifically authorized within these rules. This includes, but is not limited to, all fuel injection and engine management components, as well as electrical, cooling, and lubrication systems. All systems are subject to test procedures and must conform to OEM specifications as stated in the Mazda factory service manual.
- 2) Permitted engine maintenance includes the replacement, but not modification, of external engine and engine systems parts. No balancing, blue printing, lightening, polishing, or other modification of moving parts of the engine is permitted. All parts in the engine must be stock Mazda OEM parts unless specified in this rule set. For all Mazda part numbers in these specifications, superseding part numbers are considered equivalent.

b. Block

The engine block may be decked/milled to achieve the factory specified compression ratio for the correct model year as listed. Honing of cylinders is permitted to a maximum diameter as shown in the following table:

Model Years	Maximum Diameter (inches)
90-93	3.076
94-05	3.273

Cast iron cylinder liners (sleeves) may be installed to restore damaged or worn cylinder bores to the original dimension. Re-boring to over size is prohibited.

c. Crankshaft

The stock Mazda Miata crankshaft must be used with no modifications allowed, as shown in the following table, which also displays minimum weights (not including pilot bearing or hardware):

Model Year	Part Number	Minimum Weight (lbs)
90-93 (short nose)	B617-11-300	26.5
90-93 (long nose)	B6S7-11-300A	26.5
94-05	BP06-11-300D	35.6

Main and rod bearings must not be modified in any way. OEM bearings must be used from within the standard ranges as allowed in the Mazda factory service manual. The crank triggers must not be altered or modified in any way. The crank pulley/balancer must not be altered or modified in any way.

d. Connecting Rods

Mazda part number B6S7-11-210E must be used. Minimum connecting rod weight with cap and bolts is 537 grams.

e. Pistons

Mazda OEM standard size pistons must be used. Minimum weights less wrist pin and hardware and minimum weights of wrist pins are shown in the following table:

Model Year	Part Number	Minimum Weight (w/o wrist pin and hardware (grams)	Minimum Weight Wrist Pin (grams)
90-93	B6Z2-11-SA0C	271.5	86.0
94-97	BPY11-11-SA0A	291.5	80.0
99-00	BPZ0-11-SA0	290.0	80.0
01-05	BPZ3-11-SA0	290.00	80.0

The use of oversize pistons is not permitted. No modification of the piston is permitted. Modification of the piston ring end gap width is allowed.

f. Cylinder Head

The gasket face of the cylinder head may be resurfaced provided the maximum compression ratio is not exceeded and the minimum height of the cylinder heads are maintained. The minimum heights of the cylinder heads as measured in the factory service manual allowed are shown in the following table:

Model Years	Minimum Height (inches)
90-93 (1.6L)	5.245
94-05 (1.8L)	5.255

The cylinder head must not be ported, polished, or machined. The original casting must not be modified in any way or polished unless specified below.

The throat area of the port consists of the 90 degree angle at the very bottom of the cast steel valve seat as it transitions to the aluminum casting below. It is permitted to plunge cut the throats in order to correct for core shift that is commonly found in many cylinder heads. This cut cannot extend further than the specified number below from the bottom of the ferrous valve seat. There can be no tooling or machine marks in the head below this point. The area under the seat where the plunge cut ends and the casting resumes cannot be blended by hand, machined, or chemically processed to create a smooth transition. The 90 degree bend at the bottom of the valve seat and the aluminum directly below it will be measured with a gauge and must conform to the maximum diameters and depths listed below.

No aluminum in the bowl area (other than that specified for the plunge cut) or the ports may be removed, added, or manipulated for any reason. It is understood that heads may look slightly different from bowl to bowl due to casting irregularities. No material may be removed or added from the short turn radius in the port.

All dimensions in the following table will be measured with go/no go tooling.

Engine	Maximum Intake Throat Diameter (inches)	Maximum Exhaust Throat Dimensions (inches)	Maximum Throat Depth (from bottom of ferrous valve seat (millimeters)
1.6L	1.095	0.948	12
1.8L	1.178	1.020	9

Unshrouding of the valves is strictly prohibited. There must be a sharp edge where the valve relief cut meets the chamber. That edge must be present and unmodified. This area is **not** to be blended by hand, machined, or chemically processed to create a smooth transition. This dimension will be measured with go/no go tooling. The maximum dimensions are listed below, measuring guide centerline to chamber edge:

Engine	Maximum Intake Valve Relief Cut radius (inches)	Maximum Exhaust Valve Relief Cut radius (inches)
1.6L	0.687 Radial	0.600 Radial
1.8L	0.760 Radial	0.675 Radial

g. Camshaft

Camshafts must comply with the official camshaft specifications as supplied by the SCCA Club Racing Tech Department. The camshaft and crankshaft sprockets must be as supplied by Mazda. Cam timing must not be altered; the belt must be installed as specified in the Mazda factory service manual.

h. Valves

OEM valves must be as supplied by Mazda. Valve location or angle must not be moved. Reshaping of the valves is strictly prohibited. Valve guides may be replaced provided the position of the valve is not changed and the replacement guides are Mazda OEM parts. Valve stem installed height must be per the Mazda factory service manual: Valve stem seals must be Mazda OEM parts. Valve seats may be cut provided the valve seat angles are stock Mazda three angle cut, as defined below.

A valve job will consist of only three flat angles; radius cuts are not allowed. A 45 degree seat angle must be used, which may vary in width from .030 inch to .050 inch. To narrow or correctly position the face angle, a bottom angle of 70 degrees must be used. To narrow or correctly position the face angle, a top cut of 30 degrees may be used. All angles must stay on the cast steel block portion of the seat. The angles must not extend off the seat into the aluminum casting at the top or bottom of the seat.

i. Valve Springs

Valve springs are Mazda OEM as specified in the Mazda factory service manual. Valve spring shims are not permitted except the one standard shim that is used under every valve spring. Only the Mazda shim may be used and the OEM dimensions must be maintained.

j. Compression Ratio

Maximum allowed compression ratios are shown in the following table:

Model Years	Compression Ratio
90-93	9.4:1
94-97	9.0:1
99-00	9.5:1
01-05	10.0:1

Carbon may be removed from combustion chambers, valves, and pistons.

k. Intake Manifold

The intake manifold must be stock Mazda parts, without any material added or removed. No coating is permitted on the exterior or interior of the manifold. Injectors must be stock Mazda OEM parts, correct for the model year of the car. All air entering the intake tract shall pass through the fuel injection air inlet.

- 1.6L cars may replace the stock air box with a cone style air filter assembly. The air filter element is unrestricted. No ducting or baffling of air to the air filter is permitted.
- 1.6L cars may open and adjust, but not modify, the OEM airflow meter. For 1.6L cars, the position of the air flow meter may be moved provided it remains attached to the unmodified factory intake tube.
- 1.8L cars must use the stock air box, but the air filter element is unrestricted. Mass air flow sensors may not be modified, adjusted or opened.
- 1.8L cars must use an air restrictor plate. The restrictor plate must be placed between the throttle body and plenum. All intake air must pass through the restrictor plate. Restrictor plates must be the proper size as listed in the specification table, must be from Mazdaspeed Motorsports Development or from SCCA Enterprises, and must not be modified.

l. Fuel system

The fuel pump and fuel pressure regulator must be Mazda OEM parts and unaltered. Unleaded fuel filler trap door and restrictor plate in filler neck may be removed. Refer to GCR Section 9.3.26 for permitted fuel specifications and for the required fuel sample acquisition port.

m. Exhaust system

The exhaust manifold must be Mazda OEM, without any material added or removed. No coatings are permitted on the exterior or interior of the manifold. Heat wraps may not be used.

The 1999-05 Miatas with California emissions equipment may substitute the Federal OEM exhaust manifold and ECU for the OEM CA exhaust manifold and catalytic converter.

The post catalytic converter oxygen sensor may be disabled, replaced, relocated, or removed; the resulting hole (if present) may be plugged. Original exhaust system heat shields may be removed.

The factory exhaust system beyond the OEM front down pipe may be replaced, provided the following are true:

- The replacement system retains the original configuration (i.e., single tube design) and the tubing is a maximum of 2.25 inches outside diameter.
- The pipe may end anywhere after the rear subframe. Forward of the rear subframe, the pipe must follow the original path of the OEM exhaust system.
- No expansion chambers. A single muffler may be added.
- The system meets all event specific sound requirements.
- A catalytic converter may be gutted, removed, or replaced with a catalytic converter replacement pipe. The replacement pipe must not exceed 17.5 inches in length and have an outside diameter no greater than 2.375 inches.
- No portion of the exhaust may be wrapped with any type of insulating tape, nor shall any portion of the exhaust, internal or external, be coated with any thermal coatings.

n. Lubrication System

The oil pan must be as supplied by Mazda. No modifications are permitted. The windage tray must be used and must not be modified in any way.

o. Cooling System

- The water pump must be a Mazda or an OEM equivalent part. The water pump pulley must be the stock Mazda part. No modifications are permitted.
- Any radiator may be used, provided it is mounted in the original location, maintains the same plane as the original core, and requires no body or structure modifications to install. Any openings created by fitting an alternate radiator must be blocked to prevent air from entering the engine compartment. At least one functional stock OEM cooling fan must be maintained and mounted in the stock location.
- Thermostats may be modified, removed, or replaced.
- All cars may install the upper radiator seal, p/n NA75-50-OK7A.
- A radiator screen of 1/4 inch minimum mesh may be added in front of the radiator and contained within the bodywork.

p. Electrical Equipment

The ECU and engine electrical harness must be as supplied by Mazda. No modifications are permitted. The ECU maps and inputs must not be modified.

Ignition coils must be stock Mazda parts. No modifications are permitted.

All sensors related to engine operating parameters must be used and must be stock Mazda parts. These sensors and their locations and mounts, and their wiring harness leads may not be altered. Any sensors required for analog type gauges must be in addition to the Mazda sensors. Data acquisition sensors may be added. Relocating the oil pressure sending in order to install an oil pressure gauge is permitted.

The alternator may be OEM equivalent. The alternator drive pulley must be stock. The alternator must not be disabled in any way. Spark plugs and spark plug wires may be substituted. Ignition timing is unrestricted within stock adjustment capability.

Batteries may be replaced with those of an alternate manufacturer, provided they are of similar amp-hour capacity, size, and weight, and are fitted in the standard location. Additional battery hold-down devices may be used and are strongly recommended.

q. Flywheel

The stock Mazda flywheel must be used. No modifications are permitted except for normal resurfacing for clutch wear.

The following table provides minimum weights with pilot bearing:

Model Years	Minimum Weight (lbs)
90-93	17.6
94-05	17.0

The 94 model year may use the flywheel from the 95-05 model years. If the 1994 flywheel is used, it must weigh a minimum of 18.5 lbs.

r. Clutch

All cars must use either the stock OEM pressure plate or the ACT pressure plate (Mazdaspeed p/n: 0000-0205401-SS – 1.6L cars or 0000-0205404-AC – 1.8L cars). The unmodified pressure plate must be bolted directly to the stock, unmodified flywheel.

Any clutch disk may be used.

s. Miscellaneous

The use of the following non-standard replacement parts is permitted provided use does not result in any unauthorized modification of any other component.

- Fasteners – nuts, bolts, screws, washers, studs, etc. (Head bolts, rod bolts, flywheel bolts, and crank pulley bolt must be used as provided by Mazda.)
- Gaskets and seals, except those specified in the above rules
- Mechanical tachometer and analog gauges
- Oil and lubricants

This rewrite of the SM engine rules has been coordinated with all the major SM engine builders to achieve specifications that are clear and can be reliably enforced by tech personnel.

CAR RECLASSIFICATIONS

Production

Item 12. Lotus 7 and Lotus 7 America to HP at 1,550 lbs.

Touring/Showroom Stock

Item 13. Celica GTS to SSC, without the TRD suspension kit and limited slip, at 2,910 lbs; with Canton Accusump #24-260, sandwich #24-700, valve #24-260, and related hoses and brackets.

Item 14. 350Z may remain in T2 as specified, and may change to T3 with the following adjustments:

- 8 inch wide wheels
- 245 maximum tire size
- Remove all Nismo suspension
- Add 31 mm SIR, which will be monitored for performance
- Weight at 3,268 lbs

All reclassifications are to create more competitive places for these cars to run.

Attachment for Item 5.

GCR page ii:

©2010 Revised

SPORTS CAR CLUB OF AMERICA, INC.

All rights reserved. No part of this book may be reproduced or transmitted in any form or by means electronic or mechanical, including photocopying, recording, or by any information storage or retrieval system, without permission in writing from the Sports Car Club of America *or as allowed in this book.*

Printed in the United States of America

[~~Note: Remainder of page — Registered Trademarks — unchanged~~]

GCR page iii:

The General Competition Rules of the Sports Car Club of America are intended to assist in the orderly conduct of race events. They are in no way a guarantee against injury or death to participants, spectators, or others. No express or implied warranties of safety or fitness for a particular purpose are intended or shall result from publication of or compliance with these rules.

FOREWORD

~~The General Competition Rules (GCR) of the Sports Car Club of America are intended to assist in the orderly conduct of race events. It is hoped that the layout The organization of the GCR will should be of benefit to users. It must be remembered however, that the GCR is a reference book, and not a novel. To find the answer, the reader must first know the question. The index will help, but the Table of Contents will give a good idea of the general layout.~~

Electronic and printed editions of the GCR are available. The electronic edition may be updated during the calendar year and will be available on the SCCA web site. The electronic editions take precedence over the printed edition. Express permission is granted members and others to transmit and use the electronic editions for purposes related to SCCA Club Racing activities.

~~Effective January 1st, of each year, all editions of the SCCA General Competition Rules and all Court of Appeals rulings are superseded by the following SCCA General Competition Rules.~~

~~All dimensions are in inches unless otherwise noted.~~

~~The masculine pronouns he, him, his will be used generically, without actual reference to gender.~~

[Note: remainder of page unchanged.]

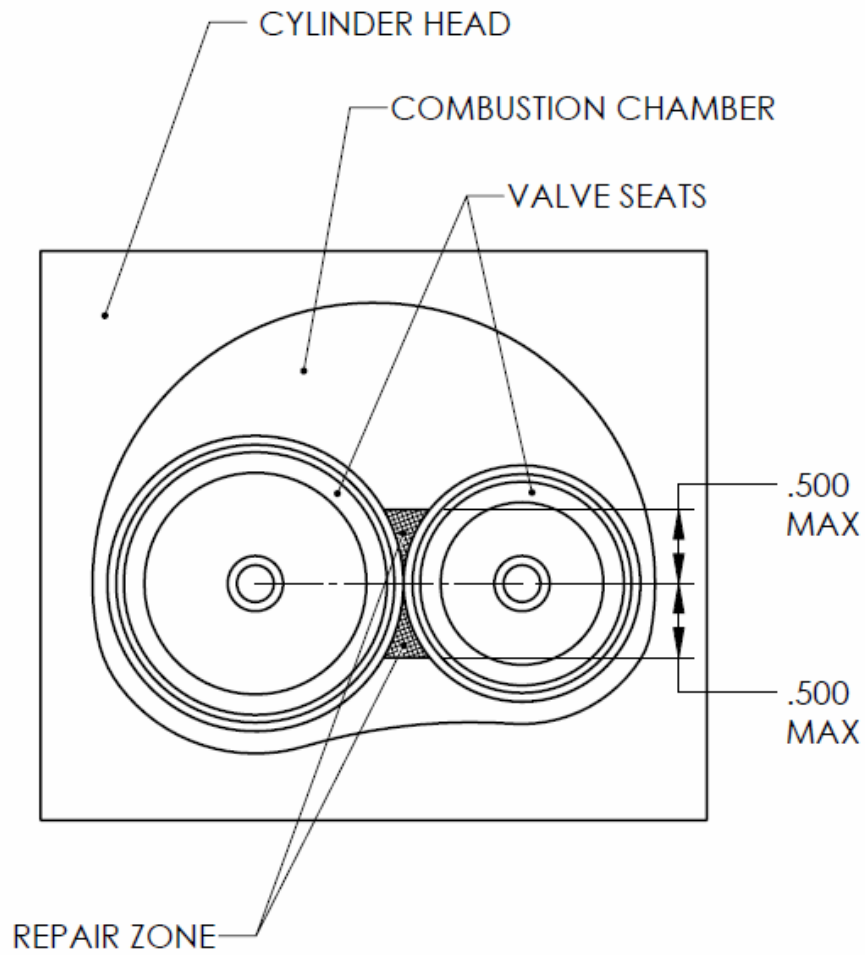
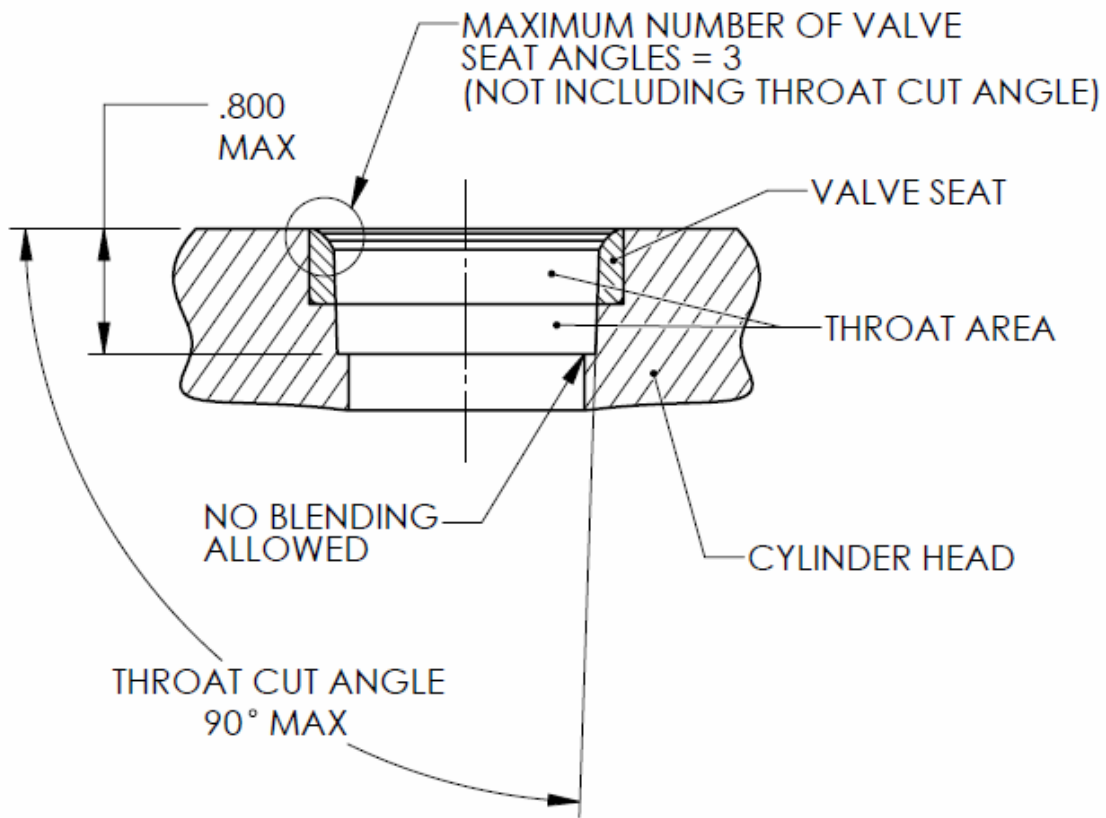

FIGURE 2. Aluminum Cylinder Head Repair Zone



DRAWING 1. Valve Seat Cutting Dimensions

The following includes the provisions for a 15 Year-Old Permit for the case where the Permit is required to be used for as long as the driver is 15 years old.

APPENDIX C: PARTICIPANT LICENSING

1. OFFICIAL'S LICENSING AND TYPES

1.1. Official

1. Regional
2. Divisional
3. National
4. Senior

1.2. Steward

1. Steward-in-training
2. Regional
2. Divisional
3. National
4. Senior

1.3. Licensing Requirements

- A. Only SCCA members may be licensed.
- B. License applications are available from Divisional Specialty Administrators, Regional Licensing Chairmen, online at the SCCA official web site, and by mail from the SCCA National Office.
- C. Except for the Senior License level, all Licenses are for one year, concurrent with the membership term.
- D. Following the initial year, the renewal minimums are as follows:
 1. Regional Renewal : Six (6) days at SCCA Sanctioned events in the preceding 12 months.
 2. National Renewal: Eight (8) days at SCCA Sanctioned events in the preceding 12 months.
 3. Senior Renewal: Must be approved by Divisional Administrator and Executive Steward every three (3) years.
- E. Anyone not meeting the participation requirements for his license (upgrade or renewal) is advised to contact his Divisional Specialty Administrator, who may waive requirements.
- F. Upgrading to the next level of license is dependent upon the specialty.
- G. License Renewal/Upgrade Forms are mailed automatically to license holders in advance of the expiration of the current License.

1.4. Licensing Minors

- A. The SCCA defines a Minor as an individual between 16 years and the age of majority as determined by the law in the state of the individual's residence (typically 18 years old, but it may vary). A Minor may apply for an SCCA Official's License.
- B. Only the National Office may issue an Official's License to a Minor. In addition to the Specialty License Application, a Minor applicant must submit the following to the National Office:
 1. A completed Parental Consent, Release and Waiver of Liability, Assumption of Risk and Indemnity Agreement. This document must be filed annually until the Minor achieves the age of majority in his state.
 2. A completed Minor's Assumption of Risk Acknowledgment.

2. COMPETITION LICENSES

2.1. Medical Requirements

- A. Everyone who applies for a Competition License or Permit must submit a completed SCCA Physician's Examination and Medical History Form. The Form must be submitted every 5 years for applicants ages 15-35; every 2 years for applicants ages 36-59; and every year for applicants age 60 and over. The examination date cannot be more than 3 months before the Competition License or Permit application date. A new Form is not required for a 15 year-old Permit holder or Novice Permit holder applying for a Regional or National License, provided the current Form is within the specified term for his age group. The Form remains valid only when a member maintains continuous SCCA membership and license.
- B. An individual may be issued a Novice Permit by a Divisional or Regional Licensing Chairman provided there is no medical condition identified on the Form which requires review by the Medical Advisory Board.
- C. Forms are available from Regions, from the National Office, and on SCCA's web site, www.scca.com.
- D. Many medical conditions affect a competitor's fitness. Certain conditions will be automatically reviewed by the Club Racing Medical Director and the Medical Review Board to determine whether a competitor should be issued a license. Specific medical conditions that preclude issuing a license are varied and change with improving medical treatments. The medical reasons for denying a license will be explained to the applicant. Actions of the Medical Review Board are final and are not subject to protest.
- E. A competitor who is issued a license under medical waiver must submit the Form annually.

2.2. Credit Toward License

- A. To qualify for renewing or upgrading a license, a competitor must participate in the minimum number of SCCA races specified in the chart, below. However, no license credit shall be given for the following:
 - 1. Drivers Schools
 - 2. Races held as part of a Drivers School
 - 3. Events not sanctioned by the SCCA
 - 4. Events resulting in a DNS or DNF
- B. A licensed competitor may enter multiple cars in an event, but will earn license credit for only one entry for each race group per sanction number. A Novice Permit holder will earn license credit for only one race for each sanction number.

2.3. Competition Licensing Requirements

The chart below shows the standard licensing requirements and progressions.

2.4. Additional Licensing Information

- A. All 15 Year-Old Permit, Novice Permit and License applications must be signed by the applicant and sent, along with all required paperwork and fees to the following address:

Sports Car Club of America, Inc.
Competition License
6700 SW Topeka Blvd., Building 300
Topeka KS 66619

- B. An applicant for any Permit or License who requests expedited processing must add an additional \$125 to the license fee shown on the chart. The special handling fee guarantees a 24 hour business day turn-around and the License is returned via Federal Express.
- C. License Renewal/Upgrade Forms are mailed automatically to Regional, Vintage, and National License holders in advance of the expiration of the current License.
- D. An applicant's Divisional Driver Licensing Administrator, or the National Administrator of Driver Licensing, or the Club Racing Department may waive some or all of the participation requirements for issuing or renewing a Regional, Vintage, or National License. Anyone not meeting the participation requirements for Regional, Vintage, or National License (upgrade or renewal) is advised to contact one of these sources to request a waiver.
- E. In addition to the basic items for each license level and upgrade in the chart above, please note the following sections, particularly with respect to licensing Minors, below.

LICENSE LEVEL	SCCA MEMBER TYPE	AGE	WHO MAY ISSUE THE LICENSE	APPLICATION	MEDICAL FORM	FEE	GCR	TERM	OTHER
15 YEAR-OLD PERMIT	Individual/Family/ First Gear in good standing	15 years old	National Office Only	Novice Permit Application	Required	\$110 (Region retains \$40)	Included	2 years (convert to Novice Permit in 2 nd year)	2 Passport Photos + Proof of Age + Parent/ Guardian Permission + Divisional Licensing Chairman Approval
NOVICE PERMIT	Individual/Family/ Spouse/First Gear older in good standing	16 years or older	National Office or National/ Divisional/ Regional Driver Licensing Administrator	Novice Permit Application	Required	\$110 (Region retains \$40)	Included	2 years	2 Passport Photos + Proof of Age + Operator's Permit/State Driver's License allowing solo motor vehicle operation
NOVICE TO REGIONAL	Same as Above	Same as Above	National Office	Completed Novice Permit + Regional License Application	When needed	\$80	Included	1 year	Complete School Requirements + 2 Regional Races on Permit + Appropriate Officials' Signatures on Permit
NOVICE TO VINTAGE	Same as Above	Same as Above	Same as Above	Completed Novice Permit + Vintage License Application	When needed	\$55	Not Included	1 year	Complete School Requirements + 2 Regional Races on Permit + Appropriate Officials' Signatures on Permit
NOVICE TO NATIONAL	Same as Above	Same as Above	Same as Above	Completed Novice Permit + National License Application	When needed	\$90	Included	2 years	Complete School Requirements + 2 Regional Races on Permit + Results of 4 Additional Regional Races. All in prior 24 months.
REGIONAL RENEWAL	Same as Above	Same as Above	Same as Above	Regional License Renewal Application	When needed	\$80	Included	1 year	Results of 2 Regional Races or 2 Vintage Races from the prior 12 months
VINTAGE RENEWAL	Same as Above	Same as Above	Same as Above	Vintage License Renewal Application	When needed	\$55	Not Included	1 year	Results of 2 Vintage Races or 2 SCCA Regional Races from the prior 12 months
REGIONAL TO NATIONAL	Same as Above	Same as Above	Same as Above	National License Application	When needed	\$90	Included	1 year	Results of 4 Regional Races from the prior 12 months on a Regional License
NATIONAL RENEWAL	Same as Above	Same as Above	Same as Above	National License Renewal Application	When needed	\$90	Included	1 year	Results of 3 SCCA National/Pro/FIA events or 2 SCCA National/Pro/FIA events + 1 Regional Races or 4 Regional Races

2.5. Licensing Minors

- A. The SCCA defines a Minor as an individual between 15 years and the age of majority as determined by the law in the state of the individual's residence (typically 18 years old, but it may vary). A Minor may apply for an SCCA Official's License.
- B. Only the Club Racing Office may issue a Novice Permit to a Minor. In addition to the paperwork and fees indicated on the chart, above, a Minor applicant must submit the following to the Club Racing Office:
 - 1. A completed Parental Consent, Release and Waiver of Liability, Assumption of Risk and Indemnity Agreement. This document must be filed annually until the Minor achieves the age of majority in his state.
 - 2. A completed Minor's Assumption of Risk Acknowledgment.
 - 3. A photocopy of both sides of his State Operator's Permit/Drivers License.
- C. Only the Club Racing Department may waive Drivers' School, Regional, Vintage, or National License participation requirements for a Minor.

2.6 15 Year-Old Permits

A 15 Year-Old Permit is a provisional license for young drivers with previous racing experience in karts, quarter-midgets, etc.

Applicants with prior racing experience in karts, quarter-midgets, etc., will be considered for a 15 Year-Old Permit. Applicants must submit a resume of their prior racing experience that will be evaluated by their Divisional Driver Licensing Administrator. If the Divisional Driver Licensing Administrator is satisfied with the applicant's experience, he will schedule an interview with the applicant to complete the evaluation. It is preferred that the interview be in person, but if necessary, a telephone interview is acceptable. If the Divisional Licensing Administrator judges that the applicant's experience and maturity is satisfactory, he will recommend to the Club Racing Office that a 15 Year-Old Permit be issued. A completed Parental Consent, Release and Waiver of Liability, Assumption of Risk and Indemnity Agreement and a completed Minor's Assumption of Risk Acknowledgment must be submitted to the Club Racing Office.

A 15 Year-Old Permit will be issued in the form of a special logbook with a distinctive cover. It must be used for all driver school and race events until the driver reaches the age of 16. If the requirements for a regional license are not fulfilled by the time the driver reaches the age of 16, the 15 Year-Old Permit shall be returned to the Club Racing Office to be replaced by a Novice Permit. Any successfully completed Driver Schools and races will be transferred to the Novice Permit.

15 Year-Old Permit logbooks may be issued only by the Club Racing Office.

At every driver school and every race, the permit logbook must be presented to the Chief Steward before participating in any on-track session. The Chief Steward will complete the appropriate logbook page at the end of the event.

At any event (school or race), the Chief Steward may recommend revocation of the logbook.

In addition to the successful completion of the required driver school(s), the Chief Steward must explicitly state that the driver is prepared to race; otherwise, additional school(s) are required.

A 15 year-old must complete his first driver school in a car from one of the following classes: FV, FST, FF, SRF, SM, HP, T3, SSB, SSC, ITA, ITB or ITC. Upon successful completion of the first school, any car may be used thereafter.

No 15 year-old will be allowed to race without having successfully completed at least one SCCA driver school. In Divisions in which SCCA driver schools are not available, the student may be allowed to race after completing two SCCA Accredited Schools subject to the approval of the Divisional Driver Licensing Administrator.

The 15 Year-Old Permit is treated as a Novice Permit for the purposes of license upgrades, however the logbook will be used as the license regardless of the events (Regional or National) for which the driver is eligible.

2.7. Novice Permit

A Novice Permit is a training license for student drivers as they develop the experience necessary to safely race with the SCCA.

- A. After submitting the required materials, an applicant will receive his Novice Permit with one photo attached. The Permit must be presented at Drivers School and subsequent SCCA races until replaced by a Competition License.
- B. A Novice Permit is valid for 24 months with continuous SCCA membership. However, Novice Permit holders over age 60 and those requiring a medical waiver must submit the Medical Form annually for the Permit to remain in effect.
- C. A Novice Permit holder who does not complete requirements to upgrade to a Regional or Vintage License by the expiration date of the Permit must start over with no credit for previous schools or races.
- D. Successful completion of 2 SCCA Drivers Schools or their equivalent is required before a Novice Permit holder may race. The following must be noted in the Novice Permit:
 - 1. A total of at least 6 hours of in-car, on-course time.
 - 2. A Satisfactory rating in at least 2 SCCA Drivers Schools.
 - 3. The Signature of the Chief Steward indicating participation in each School attended.
- E. Novice Permit holders may offer equivalencies to replace one or both SCCA Drivers Schools.

1. The Chief Steward of an SCCA Drivers School or the Novice Permit holder's Divisional Licensing Chairman may waive all or part of the Drivers School requirements for drivers with prior racing experience.
 2. The Chief Steward of an SCCA Drivers' School, the Novice Permit holder's Divisional Licensing Chairman, or the Club Racing Department may give credit for one SCCA School to a driver who submits evidence of having successfully finished an SCCA accredited private drivers' school after that driver has completed 3 hours of in-car, on-course time in SCCA Drivers School.
 3. The Chief Steward of an SCCA Drivers' School, the Novice Permit holder's Divisional Licensing Chairman, or the Club Racing Department may give credit for two SCCA Schools to a driver who submits evidence of having successfully completed two SCCA accredited private drivers' schools.
 4. Club Racing will publish the list of accredited private schools whose curricula and methods have been approved and who have submitted a service fee to the SCCA.
- F. Drivers who have fulfilled the Drivers School requirements complete the Novice Permit by successfully competing in two Regional races within the 2 year term of the Permit. The Chief Steward for each race must sign the Permit to indicate participation.

When the second Regional Race is credited, the Chief Steward or Chairman SOM for that event must also sign the Permit acknowledging completion of the Novice Permit requirements. If the Chief or Chairman will not sign the Permit, a Novice Permit holder may appeal that decision to his Divisional Licensing Chairman for a final decision.

- G. A Novice Permit may be revoked by the holder's Divisional Licensing Chairman upon the recommendation of the event Chief Steward.

2.8. Regional License

- A. A driver who has finished all Novice Permit requirements, including the acknowledgment signature of the Chief Steward or Chairman SOM, may follow the directions in the Permit to apply for an upgrade to a Regional License. For the three consecutive weekends after he has submitted his Regional License application to the National Office for processing, he may use a photocopy of the Permit as a License to race. Or he may retain the original Novice Permit to use as a License until he completes 4 Regional Races (beyond the initial 2 for the Novice Permit requirement) to earn a National License.
- B. Licenses listed in 3.1.5.C. will be accepted as equivalent to SCCA event and medical requirements for the purpose of issuing an SCCA Regional License.

2.9. National License

- A. A Regional License holder who completes requirements for a National License or who receives a waiver from his Divisional Licensing Chairman during the Regional portion of a Regional/National weekend needs only the permission of the event Chief Steward to enter the National race. Drivers competing on a 15 Year-Old Permit may not be upgraded to a National license under these circumstances.
- B. A Canadian resident holding a current ASN Professional Grade C License or higher may apply for an SCCA National License if he is an Individual, Family, Spouse, or First Gear SCCA member in good standing and submits a copy of his current ASN License and ASN Medical Form, along with the License fee.

3. CREW LICENSES

3.1. Licensing Requirements

- A. Only SCCA members may be licensed.
- B. All non-Minor SCCA members will automatically be licensed as Crew.
- C. Licenses are for one year, concurrent with the membership term.
- D. There is no participation requirement for renewal.

3.2. Licensing Minors as Crew

- A. The SCCA defines a Minor as an individual between 16 years and the age of majority as determined by the law in the state of the individual's residence (typically 18 years old, but it may vary). A Minor may apply for an SCCA Crew License.
- B. Only the National Office may issue a Crew License to a Minor. In addition to the Crew License Application, a Minor applicant must submit the following to the National Office:
1. A completed Parental Consent, Release and Waiver of Liability, Assumption of Risk and Indemnity Agreement. This document must be filed annually until the Minor achieves the age of majority in his state.
 2. A completed Minor's Assumption of Risk Acknowledgment.

4. NON-STANDARD LICENSE SITUATIONS

- A. Probation Letter as License
1. The Chairman SOM or other review committee or Court of Appeals issues a Probation Letter to temporarily replace the confiscated License of a member whose penalty is probation.
 2. The member uses the Probation Letter as a License until the terms of the probation have been met completely.
 3. When the terms are completed, the member sends the Probation Letter to the National Office and receives his License in return.

B. **Statement of Facts Affidavit in Lieu of License**

A Statement of Facts Affidavit is available ONLY to a competitor who has received a current SCCA Competition License but does not have it in his possession at the event. A competitor whose claim to have been issued an SCCA Competition License cannot be verified is subject to automatic penalty, as specified in 7.4.D.

The following includes the provisions for a 15 Year-Old Novice Permit for the case where the Permit is required to be used until the driver turns 16 or it is replaced by a National competition license. The differences between this version and the previous version are primarily in the name of the permit and how and when it is replaced. Most of the changes are in 2.5.

APPENDIX C: PARTICIPANT LICENSING

1. OFFICIAL'S LICENSING AND TYPES

1.1. Official

1. Regional
2. Divisional
3. National
4. Senior

1.2. Steward

1. Steward-in-training
2. Regional
3. Divisional
4. National
4. Senior

1.3. Licensing Requirements

- A. Only SCCA members may be licensed.
- B. License applications are available from Divisional Specialty Administrators, Regional Licensing Chairmen, online at the SCCA official web site, and by mail from the SCCA National Office.
- C. Except for the Senior License level, all Licenses are for one year, concurrent with the membership term.
- D. Following the initial year, the renewal minimums are as follows:
 1. Regional Renewal : Six (6) days at SCCA Sanctioned events in the preceding 12 months.
 2. National Renewal: Eight (8) days at SCCA Sanctioned events in the preceding 12 months.
 3. Senior Renewal: Must be approved by Divisional Administrator and Executive Steward every three (3) years.
- E. Anyone not meeting the participation requirements for his license (upgrade or renewal) is advised to contact his Divisional Specialty Administrator, who may waive requirements.
- F. Upgrading to the next level of license is dependent upon the specialty.
- G. License Renewal/Upgrade Forms are mailed automatically to license holders in advance of the expiration of the current License.

1.4. Licensing Minors

- A. The SCCA defines a Minor as an individual between 15 years and the age of majority as determined by the law in the state of the individual's residence (typically 18 years old, but it may vary). A Minor may apply for an SCCA Official's License.
- B. Only the National Office may issue an Official's License to a Minor. In addition to the Specialty License Application, a Minor applicant must submit the following to the National Office:
 1. A completed Parental Consent, Release and Waiver of Liability, Assumption of Risk and Indemnity Agreement. This document must be filed annually until the Minor achieves the age of majority in his state.
 2. A completed Minor's Assumption of Risk Acknowledgment.

2. COMPETITION LICENSES

2.1. Medical Requirements

- A. Everyone who applies for a Competition License or Permit must submit a completed SCCA Physician's Examination and Medical History Form. The Form must be submitted every 5 years for applicants ages 15-35; every 2 years for applicants ages 36-59; and every year for applicants age 60 and over. The examination date cannot be more than 3 months before the Competition License or Permit application date. A new Form is not required for a 15 year-old Permit holder or Novice Permit holder applying for a Regional or National License, provided the current Form is within the specified term for his age group. The Form remains valid only when a member maintains continuous SCCA membership and permit or license.
- B. An individual may be issued a Novice Permit by a Divisional or Regional Licensing Chairman provided there is no medical condition identified on the Form which requires review by the Medical Advisory Board.
- C. Forms are available from Regions, from the National Office, and on SCCA's web site, www.scca.com.

D. Many medical conditions affect a competitor's fitness. Certain conditions will be automatically reviewed by the Club Racing Medical Director and the Medical Review Board to determine whether a competitor should be issued a license. Specific medical conditions that preclude issuing a license are varied and change with improving medical treatments. The medical reasons for denying a license will be explained to the applicant. Actions of the Medical Review Board are final and are not subject to protest.

E. A competitor who is issued a license under medical waiver must submit the Form annually.

2.2. Credit Toward License

A. To qualify for renewing or upgrading a license, a competitor must participate in the minimum number of SCCA races specified in the chart, below. However, no license credit shall be given for the following:

1. Drivers Schools
2. Races held as part of a Drivers School
3. Events not sanctioned by the SCCA
4. Events resulting in a DNS or DNF

B. A licensed competitor may enter multiple cars in an event, but will earn license credit for only one entry for each race group per sanction number. A Novice Permit holder will earn license credit for only one race for each sanction number.

2.3. Competition Licensing Requirements

The chart below shows the standard licensing requirements and progressions.

2.4. Additional Licensing Information

A. All 15 Year-Old Novice Permit, Novice Permit and License applications must be signed by the applicant and sent, along with all required paperwork and fees to the following address:

Sports Car Club of America, Inc.
Competition License
6700 SW Topeka Blvd., Building 300
Topeka KS 66619

B. An applicant for any Permit or License who requests expedited processing must add an additional \$125 to the license fee shown on the chart. The special handling fee guarantees a 24 hour business day turn-around and the License is returned via Federal Express.

C. License Renewal/Upgrade Forms are mailed automatically to Regional, Vintage, and National License holders in advance of the expiration of the current License.

D. An applicant's Divisional Driver Licensing Administrator, or the National Administrator of Driver Licensing, or the Club Racing Department may waive some or all of the participation requirements for issuing or renewing a Regional, Vintage, or National License. Anyone not meeting the participation requirements for Regional, Vintage, or National License (upgrade or renewal) is advised to contact one of these sources to request a waiver.

E. In addition to the basic items for each license level and upgrade in the chart above, please note the following sections, particularly with respect to licensing Minors, below.

LICENSE LEVEL	SCCA MEMBER TYPE	AGE	WHO MAY ISSUE THE LICENSE	APPLICATION	MEDICAL FORM	FEE	GCR	TERM	OTHER
15 YEAR-OLD PERMIT	Individual/Family/ First Gear in good standing	15 years	National Office Only	Novice Permit Application	Required	\$110 (Region retains \$40)	Included	2 years	2 Passport Photos or State issued Photo Id+ Proof of Age + Parent/Guardian Permission + Divisional Licensing Chairman Approval
NOVICE PERMIT	Individual/Family/ Spouse/First Gear older in good standing	16 years or older	National Office or National/ Divisional/ Regional Driver Licensing Administrator	Novice Permit Application	Required	\$110 (Region retains \$40)	Included	2 years	2 Passport Photos + Proof of Age + Operator's Permit/State Driver's License allowing solo motor vehicle operation
NOVICE TO REGIONAL	Same as Above	Same as Above	National Office	Completed Novice Permit + Regional License Application	When needed	\$80	Included	1 year	Complete School Requirements + 2 Regional Races on Permit + Appropriate Officials' Signatures on Permit
NOVICE TO VINTAGE	Same as Above	Same as Above	Same as Above	Completed Novice Permit + Vintage License Application	When needed	\$55	Not Included	1 year	Complete School Requirements + 2 Regional Races on Permit + Appropriate Officials' Signatures on Permit
NOVICE TO NATIONAL	Same as Above	Same as Above	Same as Above	Completed Novice Permit + National License Application	When needed	\$90	Included	2 years	Complete School Requirements + 2 Regional Races on Permit + Results of 4 Additional Regional Races. All in prior 24 months.
REGIONAL RENEWAL	Same as Above	Same as Above	Same as Above	Regional License Renewal Application	When needed	\$80	Included	1 year	Results of 2 Regional Races or 2 Vintage Races from the prior 12 months
VINTAGE RENEWAL	Same as Above	Same as Above	Same as Above	Vintage License Renewal Application	When needed	\$55	Not Included	1 year	Results of 2 Vintage Races or 2 SCCA Regional Races from the prior 12 months
REGIONAL TO NATIONAL	Same as Above	Same as Above	Same as Above	National License Application	When needed	\$90	Included	1 year	Results of 4 Regional Races from the prior 12 months on a Regional License
NATIONAL RENEWAL	Same as Above	Same as Above	Same as Above	National License Renewal Application	When needed	\$90	Included	1 year	Results of 3 SCCA National/Pro/FIA events or 2 SCCA National/Pro/FIA events + 1 Regional Races or 4 Regional Races

2.5. Licensing Minors

A. The SCCA defines a Minor as an individual between 15 years and the age of majority as determined by the law in the state of the individual's residence (typically 18 years old, but it may vary). A Minor may apply for an SCCA Official's License.

B. Only the Club Racing Office may issue a Novice Permit to a Minor. In addition to the paperwork and fees indicated on the chart, above, a Minor applicant must submit the following to the Club Racing Office:

1. A completed Parental Consent, Release and Waiver of Liability, Assumption of Risk and Indemnity Agreement. This document must be filed annually until the Minor achieves the age of majority in his state.
2. A completed Minor's Assumption of Risk Acknowledgment.
3. A photocopy of both sides of his State Operator's Permit/Drivers License.

C. Only the Club Racing Department may waive Drivers' School, Regional, Vintage, or National License participation requirements for a Minor.

2.6 15 Year-Old Novice Permits

A 15 Year-Old Novice Permit is a provisional license for young drivers with previous racing experience in karts, quarter-midgets, etc.

Applicants with prior racing experience in karts, quarter-midgets, etc., will be considered for a 15 Year-Old Novice Permit. Applicants must submit a resume of their prior racing experience that will be evaluated by their Divisional Driver Licensing Administrator. If the Divisional Driver Licensing Administrator is satisfied with the applicant's experience, he will schedule an interview with the applicant to complete the evaluation. It is preferred that the interview be in person, but if necessary, a telephone interview is acceptable. If the Divisional Licensing Administrator judges that the applicant's experience and maturity is satisfactory, he will recommend to the Club Racing Office that a 15 Year-Old Novice Permit be issued. A completed Parental Consent, Release and Waiver of Liability, Assumption of Risk and Indemnity Agreement and a completed Minor's Assumption of Risk Acknowledgment must be submitted to the Club Racing Office.

A 15 Year-Old Novice Permit will be issued in the form of a Novice Permit with a distinctive cover. It must be used for all driver school and race events until the driver reaches the age of 16. If the requirements for a regional license are not fulfilled by the time the Novice Permit expires, the 15 Year-Old Novice Permit shall be returned to the Club Racing Office to be replaced by a Novice Permit. Any successfully completed Driver Schools and races will be transferred to the new Novice Permit.

15 Year-Old Novice Permit logbooks may be issued only by the Club Racing Office.

At every driver school and every race, the permit logbook must be presented to the Chief Steward before participating in any on-track session. The Chief Steward will complete the appropriate logbook page at the end of the event.

At any event (school or race), the Chief Steward may recommend revocation of the logbook.

In addition to the successful completion of the required driver school(s), the Chief Steward must explicitly state that the driver is prepared to race; otherwise, additional school(s) are required.

A 15 year-old must complete his first driver school in a car from one of the following classes: FV, FST, FF, SRF, SM, HP, T3, SSB, SSC, ITA, ITB or ITC. Upon successful completion of the first school, any car may be used thereafter.

No 15 year-old will be allowed to race without having successfully completed at least one SCCA driver school. In Divisions in which SCCA driver schools are not available, the student may be allowed to race after completing two SCCA Accredited Schools subject to the approval of the Divisional Driver Licensing Administrator.

The 15 Year-Old Novice Permit is treated as a Novice Permit for the purposes of licensing while participating in Driver Schools and Regional events.

2.7. Novice Permit

A Novice Permit is a training license for student drivers as they develop the experience necessary to safely race with the SCCA.

A. After submitting the required materials, an applicant will receive his Novice Permit with one photo attached. The Permit must be presented at Drivers School and subsequent SCCA races until replaced by a Competition License.

B. A Novice Permit is valid for 24 months with continuous SCCA membership. However, Novice Permit holders over age 60 and those requiring a medical waiver must submit the Medical Form annually for the Permit to remain in effect.

C. A Novice Permit holder who does not complete requirements to upgrade to a Regional or Vintage License by the expiration date of the Permit must start over with no credit for previous schools or races.

D. Successful completion of 2 SCCA Drivers Schools or their equivalent is required before a Novice Permit holder may race. The following must be noted in the Novice Permit:

1. A total of at least 6 hours of in-car, on-course time.
2. A Satisfactory rating in at least 2 SCCA Drivers Schools.
3. The Signature of the Chief Steward indicating participation in each School attended.

E. Novice Permit holders may offer equivalencies to replace one or both SCCA Drivers Schools.

1. The Chief Steward of an SCCA Drivers School or the Novice Permit holder's Divisional Licensing Chairman may waive all or part of the Drivers School requirements for drivers with prior racing experience.
2. The Chief Steward of an SCCA Drivers' School, the Novice Permit holder's Divisional Licensing Chairman, or the Club Racing Department may give credit for one SCCA School to a driver who submits evidence of having successfully finished an SCCA accredited private drivers' school after that driver has completed 3 hours of in-car, on-course time in SCCA Drivers School.
3. The Chief Steward of an SCCA Drivers' School, the Novice Permit holder's Divisional Licensing Chairman, or the Club Racing Department may give credit for two SCCA Schools to a driver who submits evidence of having successfully completed two SCCA accredited private drivers' schools.
4. Club Racing will publish the list of accredited private schools whose curricula and methods have been approved and who have submitted a service fee to the SCCA.

F. Drivers who have fulfilled the Drivers School requirements complete the Novice Permit by successfully competing in two Regional races within the 2 year term of the Permit. The Chief Steward for each race must sign the Permit to indicate participation.

When the second Regional Race is credited, the Chief Steward or Chairman SOM for that event must also sign the Permit acknowledging completion of the Novice Permit requirements. If the Chief or Chairman will not sign the Permit, a Novice Permit holder may appeal that decision to his Divisional Licensing Chairman for a final decision.

G. A Novice Permit may be revoked by the holder's Divisional Licensing Chairman upon the recommendation of the event Chief Steward.

2.8. Regional License

A. A driver who has finished all Novice Permit requirements, including the acknowledgment signature of the Chief Steward or Chairman SOM, may follow the directions in the Permit to apply for an upgrade to a Regional License. For the three consecutive weekends after he has submitted his Regional License application to the National Office for processing, he may use a photocopy of the Permit as a License to race. Or he may retain the original Novice Permit to use as a License until he completes 4 Regional Races (beyond the initial 2 for the Novice Permit requirement) to earn a National License.

B. Licenses listed in 3.1.5.C. will be accepted as equivalent to SCCA event and medical requirements for the purpose of issuing an SCCA Regional License.

2.9. National License

A. A Regional License holder who completes requirements for a National License or who receives a waiver from his Divisional Licensing Chairman during the Regional portion of a Regional/National weekend needs only the permission of the event Chief Steward to enter the National race. Drivers competing on a 15 Year-Old Novice Permit may not be upgraded to a National license under these circumstances.

B. A Canadian resident holding a current ASN Professional Grade C License or higher may apply for an SCCA National License if he is an Individual, Family, Spouse, or First Gear SCCA member in good standing and submits a copy of his current ASN License and ASN Medical Form, along with the License fee.

3. CREW LICENSES

3.1. Licensing Requirements

- A. Only SCCA members may be licensed.
 - B. All non-Minor SCCA members will automatically be licensed as Crew.
 - C. Licenses are for one year, concurrent with the membership term.
- D. There is no participation requirement for renewal.

3.2. Licensing Minors as Crew

A. The SCCA defines a Minor as an individual between 16 years and the age of majority as determined by the law in the state of the individual's residence (typically 18 years old, but it may vary). A Minor may apply for an SCCA Crew License.

B. Only the National Office may issue a Crew License to a Minor. In addition to the Crew License Application, a Minor applicant must submit the following to the National Office:

1. A completed Parental Consent, Release and Waiver of Liability, Assumption of Risk and Indemnity Agreement. This document must be filed annually until the Minor achieves the age of majority in his state.
 2. A completed Minor's Assumption of Risk Acknowledgment.

4. NON-STANDARD LICENSE SITUATIONS

A. Probation Letter as License

1. The Chairman SOM or other review committee or Court of Appeals issues a Probation Letter to temporarily replace the confiscated License of a member whose penalty is probation.
2. The member uses the Probation Letter as a License until the terms of the probation have been met completely.
3. When the terms are completed, the member sends the Probation Letter to the National Office and receives his License in return.

B. Statement of Facts Affidavit in Lieu of License

A Statement of Facts Affidavit is available ONLY to a competitor who has received a current SCCA Competition License but does not have it in his possession at the event. A competitor whose claim to have been issued an SCCA Competition License cannot be verified is subject to automatic penalty, as specified in 7.4.D.

Appendix C: TTAC Rules Changes

The Time Trials Administrative Council recommends the following changes be incorporated into the 2010 TTR.

Submitted by: Matt Rowe - TTAC Chairman

Item 1. Effective 1/1/10: Reason for change – correction to other accepted licenses.

Change the second sentence of section (L1 & L2 - 7.3, L3 & L4 7.6) as follows:

The following competition licenses are accepted for Time Trials events, SCCA Professional, National, Regional, Vintage and Novice. Also accepted are ~~Canadian ASN and Canada FIA~~ *Canadian ASN-FIA license*. Other types of competition licenses may be accepted per Supplemental Regulations. Any of the accepted competition licenses must meet the eligibility requirements in 7.3.1.

Item 2. Effective 1/1/10: Reason for change – update to reflect current membership programs..

Change the first sentence of section (L1 & L2 7.3.1, L3 & L4 7.6.1) as follows:

Entrants with other types of accepted competition licenses must be current SCCA Regular, Spouse or, First Gear, or Family members in good standing and shall have completed the minimum number of events required for the applicable competition license during the license year.

Item 3. Effective 1/1/10: Reason for change – simplification of volunteer license renewal.

Change the first paragraph of section (L1 & L2 7.6, L3 & L4 7.11) as follows:

1. TT Volunteer
2. TT Driving Instructor
3. TT Chief Steward
4. TT Safety Steward
5. TT Tech Inspector
6. TT Course Inspector

~~The apprentice grade of any of the above licenses may be issued by any current Regional Executive or anyone holding a Specialist grade license in the category to be issued.~~

Item 4. Effective 1/1/10: Reason for change – simplification of volunteer license renewal.

Change the paragraph of section (L1 & L2 7.6.1, L3 & L4 7.11.1) as follows:

- A. ~~Apprentice~~
- B. ~~Official~~
- C. ~~Specialist~~

~~Please note that in Time Trials, these designations are awarded upon demonstration of ability and experience first, with amount of participation as a lesser consideration. The Apprentice grade shall be used for those in training and unless expressly stated within the TTR shall have an Official license holder of the same speciality onsite. Official licensees are those who demonstrate competent service and have completed an acceptable Apprentice period. The Specialist grade will designate those who are capable of taking on leadership positions. Specialists will be responsible for training new Apprentices, and will be those who are eligible for Divisional leadership positions.~~

In the Time Trial program, these designations are awarded upon demonstration of ability and experience first, with amount of participation as a secondary consideration.

- a. Apprentice - This grade shall be used for those in training and unless expressly stated within the TTR shall have an Official license holder of the same speciality onsite. Obtaining this level of license requires no approval and can be issued by contacting SCCA National office.
- b. Official - For those who demonstrate competent service and have completed an acceptable Apprentice period. This requires an upgrade request.

- c. **Specialist** – This grade designates those who are capable of taking on leadership positions. They will be responsible for training new Apprentices, and will be those who are eligible for Divisional leadership positions. This requires an upgrade request.

Item 5. Effective 1/1/10: Reason for change – simplification of volunteer license renewal.

Change the first paragraph of section 7.6.2 as follows:

~~The following participation guidelines are recommended for license upgrades:~~

- ~~1. License upgrades (except TT Safety Steward or TT Course Inspector) from Apprentice to Official may be obtained upon successful completion of 3 Time Trials events (in any combination) at the Apprentice grade. It is highly recommended that if possible, 2 of the 3 events should be Club Trials (Level 2) or higher.~~
- ~~2. TT Safety Steward or TT Course Inspector licenses may only be upgraded to Official licenses after completing an SCCA approved safety seminar and successful completion of 4 Time Trials events (in any combination) at the apprentice grade. It is highly recommended that if possible, 3 of the 4 events should be Track Trials (Level 3) or higher.~~
- ~~3. Successful completion of Apprentice grade event participation shall be documented and submitted with the license upgrade application. Documentation shall include the date, location, sanction number, specialty worked and signature of the specialty Official.~~
- ~~4. All license upgrades from Apprentice to Official shall be submitted to the TT Divisional Program Manager for approval.~~
- ~~5. The TT Divisional Program Manager shall endorse all approved licenses for upgrade to the Official grade of license being applied for.~~
- ~~6. All license upgrades to Official approved by the TT Divisional Program Manager, must be submitted to the Club Racing Manager for final review and approval prior to license issue.~~
- ~~7. License upgrades from Official to Specialist may be obtained upon completion of 7 Time Trials events (in any combination) at the Official grade. It is highly recommended that if possible, 2 of the events should be Club Trials (Level 2) and 4 of the events should be Track Trials (Level 3) or higher.~~
- ~~8. License upgrades from Official to Specialist grade of any TT license must be submitted to and approved by the Time Trials Administrative Council after being approved by the TT Divisional Program Manager and before being submitted to the Club Racing Manager for final review and approval prior to issue.~~

The following participation guidelines are recommended for license upgrades. Submit all upgrades on a Time Trial Official application. Information shall include the date, location/event, sanction number, specialty worked and signature, membership number of the specialty Official.

1. Apprentice to Official level upgrade requirements (except TT Safety Steward or TT Course Inspector)
 - a. Successful completion of 3 Time Trial events in any combination
 - b. Highly recommended 2 of the 3 events be Club Trials (Level 2) or higher
2. Apprentice to Official level upgrade for TT Safety Steward or TT Course Inspector
 - a. Completing an SCCA approved safety seminar
 - b. Successful completion of 4 Time Trial events in any combination
 - c. Highly recommended 3 of 4 events be Track Trials Level 3 or higher
3. Approval for Apprentice to Official upgrades will be submitted to and approved by the TT Divisional Program Manager. The application will be forward to Member Services for processing.

Item 6. Effective 1/1/10: Reason for change – Correction to arm restraint requirements based on TTSC assessment and recommendation.

Change the paragraph of section (L1 & L2 12) as follows:

A seven-point restraint harness is recommended for all events. Arm restraints are required optional on all cars but recommend

on all open cars including open Targa tops, sunroofs and T-tops. The restraint system installation is subject to approval of the Chief Technical and Safety Inspector.